

Code No: 152AG

R18

JAWAHARLAL NEHRU TECHNOLOGICAL UNIVERSITY HYDERABAD

B. Tech I Year II Semester Examinations, February - 2025

ENGINEERING GRAPHICS  
(Computer Science and Engineering)

Time: 3 Hours

Max Marks: 75

Answer any five questions  
All questions carry equal marks

---

- 1.a) Draw a Parabola with the distance between its focus and directrix equal to 75mm and eccentricity equal to 1.  
b) Draw a cycloid generated by a point 'P' on the circumference of a circle of diameter 60 mm when the circle rolls along a straight line. Draw a normal and a tangent to the curve at any convenient point. [7+8]

OR

- 2.a) Construct a hyperbola whose vertex is 65 mm from the focus. Draw the conic section if the eccentricity is  $\frac{3}{2}$ . Also draw the tangent and normal to it at any point.  
b) Construct a plain scale to show meters when 1 cm represents 4 meters and long enough to measure up to 50 meters. Find the R.F and mark on it a distance of 36 meters. [8+7]

- 3.a) Draw the projections of the following points on the same ground line, keeping the distance between projectors equal to 30mm.  
i) Point A, 25 mm above the HP, 30mm behind the VP  
ii) Point B, 20 mm below the HP, 25 mm behind the VP  
iii) Point C, 30 mm below the HP, 25 mm in front of VP  
iv) Point D, 25 mm above the HP, 30 mm in front of VP  
v) Point E, in the HP, 25 mm behind the VP  
b) A line AB 80 mm long has end 'A' 10 mm above HP and end 'B' 10 mm in front of VP. The line is inclined at  $30^\circ$  to HP and  $40^\circ$  to VP. Draw the projections. [7+8]

OR

- 4.a) A line MN, 70 mm long has its end 'M', 10 mm above HP and 15 mm in front of VP. The top and front views of the line have lengths of 60 mm and 40 mm respectively. Draw the projections of the line and find its true inclinations with VP and HP.  
b) Draw the projections of pentagon ABCDE of side 25 mm is inclined to VP at  $60^\circ$  and perpendicular to HP with one side perpendicular to HP. [8+7]

- 5.a) A cone is freely suspended from a point on its rim of the base so that the vertical plane containing the axis is inclined at  $60^\circ$  to the VP. Draw the projections of the cone if the diameter of the base of the cone is 50 mm and the axis is 45 mm long.  
b) A Square pyramid of 50 mm side of base and 60 mm length of axis is resting on one of its triangular faces on the H.P. having a slant edge containing that face parallel to the V.P. Draw the projections of the pyramid [7+8]

OR

QA QA QA QA QA QA QA QA QA

6.a) A pentagonal pyramid having base edge 30 mm and axis 70 mm long is resting on one of its triangular faces in HP and having axis parallel to VP. Its axis making  $30^\circ$  to XY line. Draw its plan of elevation.

b) A cone of 50 mm base diameter and axis 65 mm is suspended from a point on the base. Draw its plan and elevation. [7+8]

7. A cone of diameter 60 mm and height 80 mm is cut by a section plane such that the plane passes through the mid-point of the axis and tangential to the base circle. Draw the development of the lateral surface of the bottom portion of the cone. [15]

OR

8. A pentagon prism of 25 mm base edges and 50 mm long, resting on its base with an edge of base at  $45^\circ$  to the VP. The prism is cut by a section plane inclined at  $30^\circ$  to the HP and passes through a point 25 mm from the base along its axis. Develop its lateral surface of the truncated prism. [15]

9. Draw the orthographic views of the following figure 1. All dimensions are in 'mm'. [15]

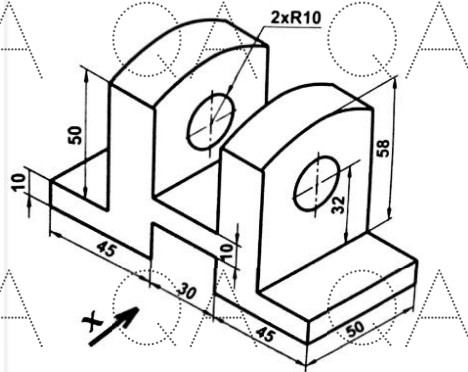

Figure.1

OR

10. Draw the isometric view of the following figure 2. All dimensions are in 'mm'. [15]

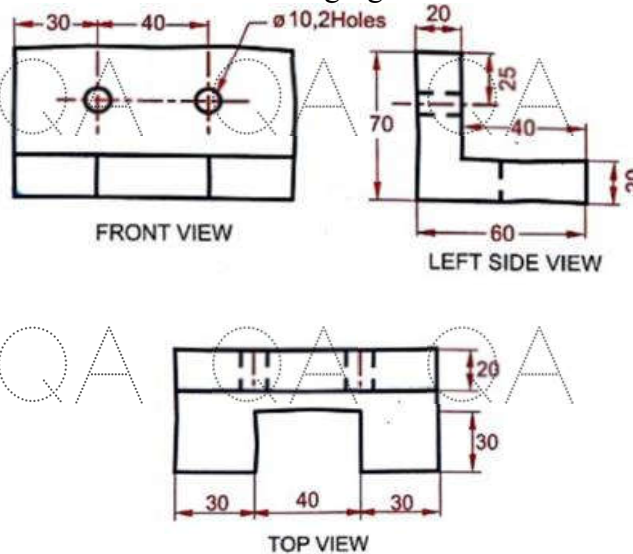

Figure.2